

TOP (PLAN) VIEW

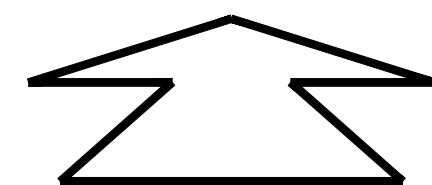

DIRECTION OF VEHICLE ATTACK

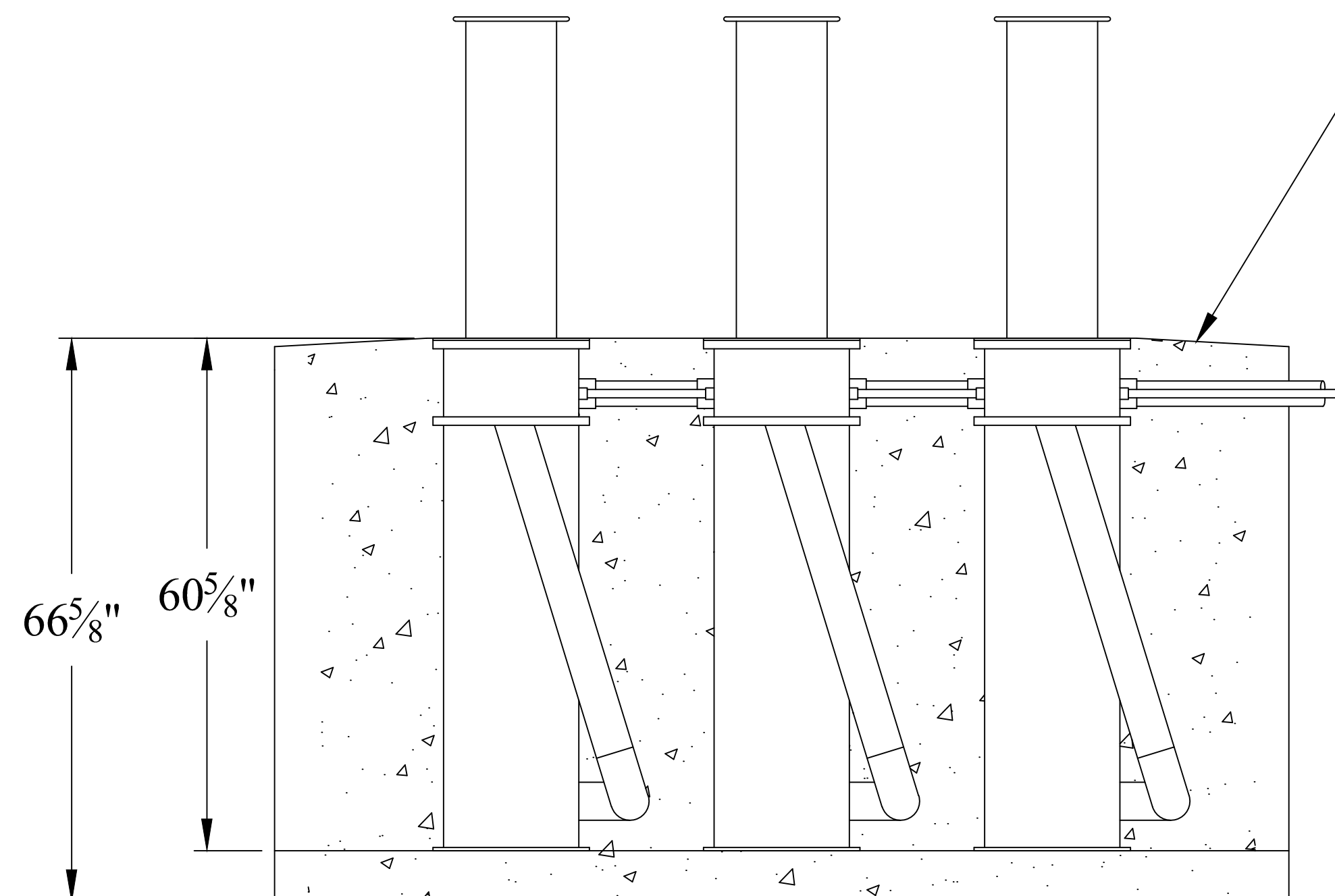

FRONT (ELEVATION) VIEW

NOTES:

1. THE TITAN IS K12 CERTIFIED BY THE U.S. DEPARTMENT OF STATE.
2. STANDARD DOS CRASH RATING BOLLARD SPACING IS NOT TO EXCEED 48 INCHES.
3. STANDARD CONFIGURATION WITH 3 BOLLARDS SHOWN. ADDITIONAL BOLLARD CONFIGURATIONS ARE AVAILABLE.
4. OUTER CASING IS HOT DIP GALVANIZED FOR CORROSION PROTECTION
5. BLACK PAINT IS STANDARD. CUSTOM SPECIFIED PAINT COLORS ARE AVAILABLE.
6. HEATERS ARE AVAILABLE FOR COLD WEATHER APPLICATIONS.
7. HYDRAULIC POWER UNIT (HPU) AND OPERATOR CONTROL PANELS ARE NOT SHOWN.
8. WEATHER-PROOF HPU ENCLOSURE IS STANDARD.
9. TRAFFIC SIGNAL LIGHTS, WARNING LIGHTS, VEHICLE DETECTOR LOOPS, AND OTHER ACCESSORIES ARE AVAILABLE.
10. UP TO 4 INCHES OF DECORATIVE ROADWAY MATERIAL CAN BE USED AROUND BARRIER.
11. CONSTRUCTION AND INSTALLATION BY OTHERS; SUCH AS CONCRETE FOUNDATION, REBAR, ROADWAY SURFACE, CONDUIT, WIRING, AND HYDRAULIC HOSES.

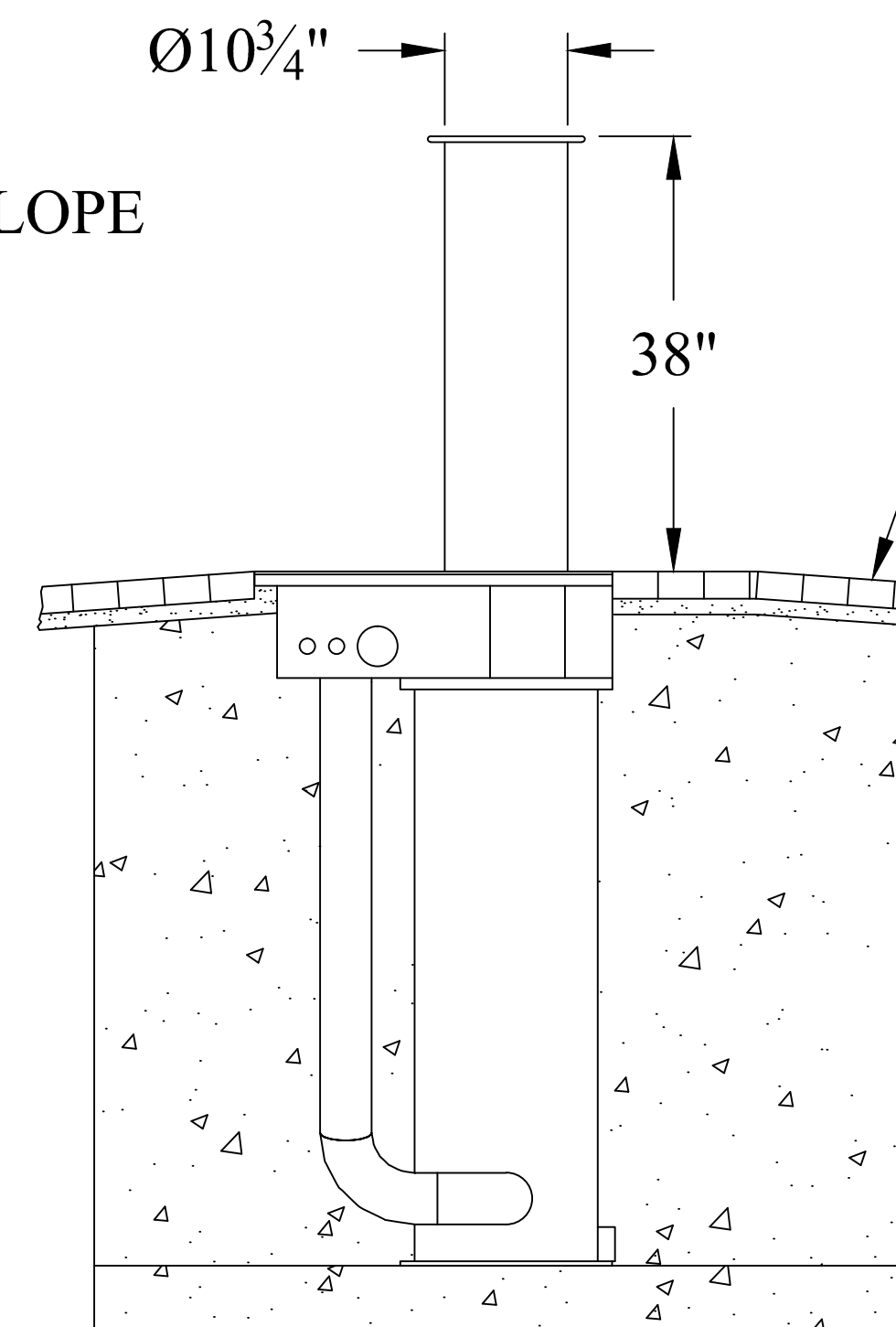

SIDE (ELEVATION) VIEW

BEVEL RUN-OFF SLOPE

CUSTOMER-DEFINED OPTIONAL ROADWAY SURFACE TREATMENT (COMPLIES WITH CRASH RATING USING ANY PAVERS, ASPHALT, ETC.)

Unless Noted Otherwise		DO NOT SCALE		PROPRIETARY INFORMATION	
.x	Decimal ± .040	DO NOT SCALE		This drawing is the proprietary property of AMERISTAR, Tulsa, OK and must not be duplicated or used in whole or in part for the making of drawings, prints or parts to the detriment of, or harm to, the owner. In accepting this drawing, the recipient agrees to keep the information contained confidential.	
.xx	Decimal ± .030	OFF DRAWING			
.xxx	Decimal ± .020				
.xxxx	Decimal ± .010	Angular ± 0.5°			
REVISION HISTORY					
REV	ECN	AUTHOR	DATE	DESCRIPTION	
A		INIT	DATE	Initial Release	
				TITLE: TITAN ARCHITECTURE DRAWING	
				DATE: 03/14/16	SHEET: 1 of 1
				DRN BY: DM	REV: A
				DRAWING NO: PART NUMBER	



1555 N. Mingo
Tulsa, OK 74116
1-888-333-3422
www.ameristarfence.com